

Cavity

MANUAL E-LONGBOARD

VERSION: CS2

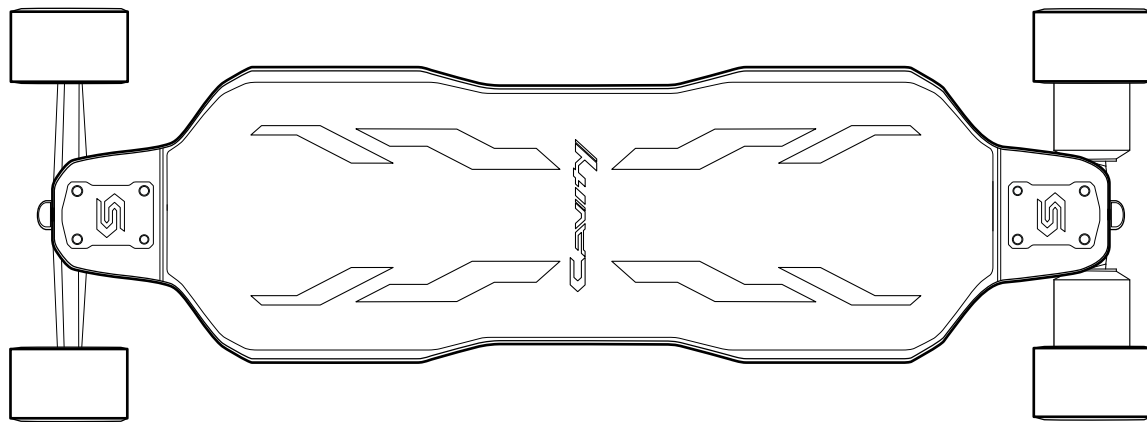

THIS MANUAL APPLIES TO ELECTRIC LONGBOARDS
OF THE CS SERIES FROM CAVITY



OVERVIEW

INTRODUCTION	01
PRECAUTIONS	02
REMOTE CONTROL	06
OPERATING INSTRUCTIONS.....	07
WARNINGS IN CASE OF MALFUNCTION	13
SAFE DRIVING	16
CARE AND MAINTENANCE	18
SAFETY INSTRUCTIONS	21
WARRANTY	21
DEVELOPER MODE	24



01 / INTRODUCTION

Congratulations on your new Cavity Electric Longboard (hereinafter referred to as E-Longboard)! The product is an innovative E-longboard for everyday use. Before each (especially before the first ride) the operational capability of the E-Longboard, especially whether wheels are damaged or components are loose. If you notice any anomalies, contact Cavity customer service and email us at support@cavityboards.com. This user manual can help you understand, use and maintain your E-longboard.

Please read this user manual carefully and observe the information contained herein before using our E-Longboard. If you give this e-longboard to others, please make sure that they also inform themselves by reading this user manual before using the E-Longboard. Please note that we have not been able to exclude the possibility of collisions, falls and loss of control. Please be careful and learn how to use the E-longboard safely.

We cannot accept responsibility for any damage caused by ignoring the user manual or other legal regulations (in particular the road traffic regulations) are not observed or our E-Longboard is used in a non-functional condition.

02 / PRECAUTIONS

1. Keep the E-Longboard out of reach of minors or other persons in need of protection.
2. The E-Longboard is only approved for use by one person and up to a maximum total load of 440 lbs.
3. Read this user manual carefully to understand the acceleration, braking and steering of the E-Longboard.
4. Riding E-longboards is dangerous. Assess the risks before you use it, take safety measures, use appropriate protective equipment (especially helmet, protective clothing, pads, etc.) and do not use the E-longboard on dangerous paths.
5. Use the E-Longboard only if you are already skilled in the use of a non-electric longboard. Do not use this E-longboard in environments where you would not use a non-electric longboard.
6. Do not use the e-longboard in case of impaired vision (also: fog), sense of equilibrium or reaction abilities for whatever reason (e.g. also due to alcohol, medication, fatigue).
7. Always keep a sufficient distance to other persons, vehicles and objects. In particular pedestrians, children and animals. Their behavior cannot always be calculated.
8. Always be attentive and cautious around an e-longboard, regardless of whether you are riding it yourself or if someone else is guiding it. Avoid risks!



9. Before starting each ride, check that all screws are tight and no parts are loose.
10. Practice starting up and braking several times each time you take off to ensure that the respective thrust you are not caught off guard and an accident or other damage is caused.
11. Check the charge level of the two batteries before starting each journey. If in doubt, charge them or replace them if a full charge is no longer possible by recharging.
12. Avoid anything (clothing (including shoelaces), body parts (including hair), bags) that could get caught in rotating parts (e.g. motor/wheels).
13. ALWAYS follow the local road traffic regulations in your area and check where you are allowed to drive. Currently, riding on the road and on the bike path is not permitted. Check the local regulations that apply in your area.
14. Only use the E-Longboard on a safe surface. Avoid water, wet surfaces, slippery/uneven surfaces, steep hills, traffic lanes, cracks, ruts, gravel, rocks, or any other obstacles that could cause loss of traction and a fall.
15. Avoid stunts or tricks (including jumps, curb grinding, racing). This E-Longboard is not designed for such use. Such use would therefore be abusive.
16. Always guide the e-longboard in such a way that in the event of a malfunction you can bring it to a stop using "classic techniques" without any health risk for you or others (braking with the foot, sliding, etc.).
17. After finishing the drive, do not touch moving parts or parts connected to them, as they can heat up due to use, which can cause burns. Before touching the E-Longboard cool down and carefully test the heat of the corresponding parts to avoid burns.

18. Our E-longboard comes with a rechargeable battery. To preserve the life and strength of the battery, protect them from heat and from extreme cold. So especially do not leave them near fire, hot environments or under direct sunlight for a long time. The E-Longboard therefore also do not leave it in a car that is parked in the sun.
19. Do not immerse the E-Longboard in water. Avoid puddles and riding in the rain. Especially the area inside the battery compartment is not water protected. Moisture in the battery compartment can cause electrical malfunctions or even a fire. If the E-Longboard gets wet, stop using it and wait until it is completely dry. And only resume operation after it is completely dry.
20. Opening the housing as well as any modifications to the E-Longboard will result in the expiry of the operating license and the right of return.
21. Avoid braking downhill for long periods with a fully charged battery. This can lead to overcharging and damage to the battery and damage to the E-Longboard. Discharge some energy beforehand!
22. If the E-Longboard should fail, the wheels block etc., please contact the Customer Service and inform them about the failure. Repairs are only allowed by the manufacturer or a certified specialist company.

【 WARNING 】

AVOID WATER!



Your E-Longboard is not waterproof. Electronics, bearings and other components may be damaged. Water damage is not covered under warranty.

DANGER OF CROSSING!



Keep fingers, hair and clothing away from motors, wheels and all moving parts.

DANGER OF ELECTRIC SHOCK!



Do not open the housing as this will void the warranty and you could get an electric shock.

Vermeiden Sie die folgenden Situationen:

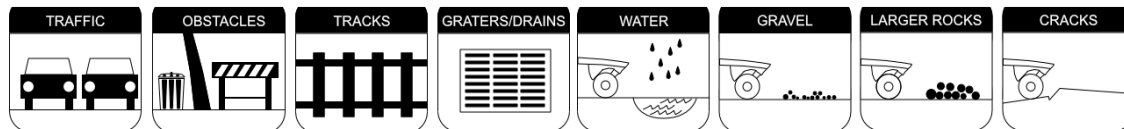

【 Overview 】

Please read ALL information in this user manual before operating your E-Longboard operation.

03 / REMOTE CONTROL

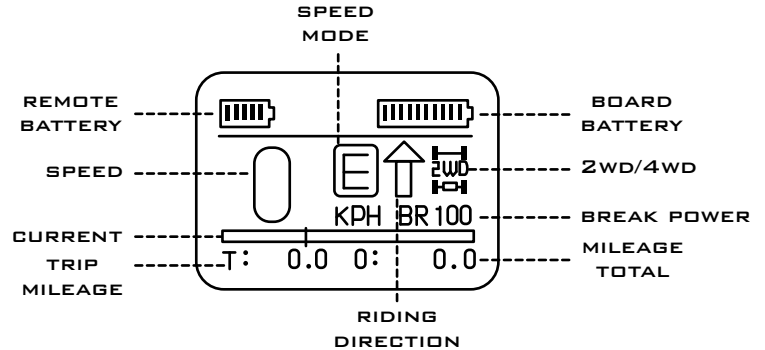
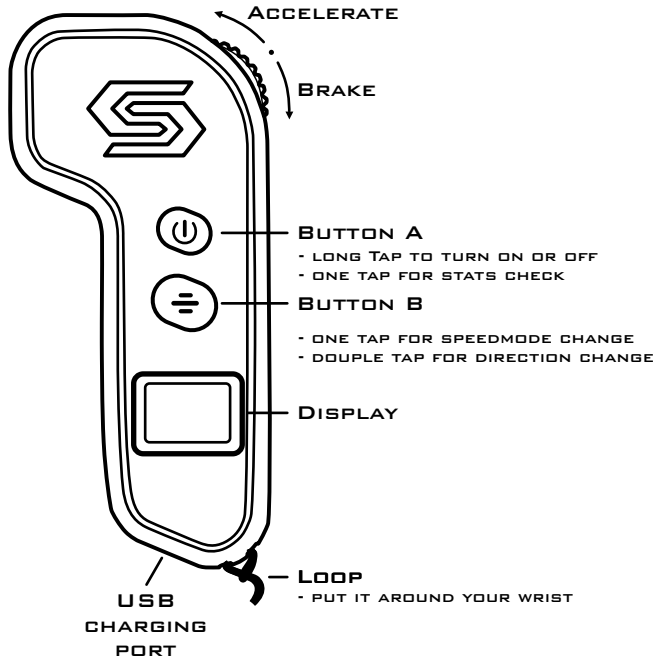



04 / OPERATING INSTRUCTIONS

(1) Switching on the remote control and the e-longboard

Press the "A" button on the remote control for 1 second to turn it on. The remote control will briefly vibrate and display the company logo. The OLED screen will display "Not Connected" for 1 second. The E-Longboard will then turn on by itself and connect. The data of the E-Longboard is now displayed on the OLED screen.

Note: The normal state after connection is that the OLED screen displays the data of the E-Longboard and the indicator light of the E-Longboard is constantly on.

If the indicator light of the E-Longboard does not light up, please press the power button on the E-Longboard for 1 second.

(2) Switch off

Manual Power Off: Press the power button on the e-longboard for 1 second to turn it off (the e-Longboard cannot be switched off when you accelerate). The remote control vibrates briefly. Press the "A" button on the remote control for 1 second to turn it off as well.

Note: If the e-longboard is turned off, but the remote control is not and is in the connection state, the remote control screen will display "not connected" and the remote control will vibrate briefly as a reminder. If the remote control is turned off in the connected state, the E-Longboard will begin to break and turns off after 5 minutes of standstill.

Automatic power off: The remote control and the e-longboard will automatically turn off if they are not operated within 5 minutes after the E-Longboard comes to a standstill.

(3) Connect and customize

The remote control and the E-Longboard are switched off. First press the power button of the E-Longboard for 5seconds, the indicator light will turn red and flash quickly to let you know that you are entering "Matching-mode". Press "A" button on the remote control for 5 seconds, the screen will display "Matching" and enter "Matching Mode".

With two short vibrations and one long vibration, the matching is completed.

After that, the indicator light of the E-Longboard is constantly on.

Now you can make changes in the settings of the E-Longboard. Adjustments can be made to the unit of the speed, whether it is a hub or belt drive, the diameter of the wheels and the number of poles of the motor.

(Changes to the motor type or the number of poles may only be made by a certified specialist company. Modifications made by others will invalidate the operating permit. Damages that caused in this way are not covered by the warranty).

Slide the scroll wheel of the remote control, to select the respective option.



(4) Battery indicator

Battery level of the remote control:

If the battery of the remote control

is less than 10% (it can be used for no more than 30 minutes).

The remote control screen will indicate that the power is less than 10% with a double long vibration. The battery should already be recharged.

If the battery of the remote control has reached 5%, it will also vibrate twice. The now available battery life is approx. 15 minutes. The battery should already be charged now.

If the voltage has reached a critical range (5%) and is connected to the E-Longboard, the remote control will vibrate once and switches off automatically.

Battery status of the e-longboard:

If the battery of the E-Longboard is lower than 25%, this will be displayed on the OLED screen of the remote control and it will vibrate 2 times.

If the battery of the E-Longboard is lower than 10%, a warning is also displayed via the remote control. warning is displayed via the remote control. This then vibrates again 2 times.

If the voltage is less than 10%, you should stop the operation immediately.
terminate.

(5) Acceleration-/brake control

Turn the control wheel (see page 6 of this operating manual) forward to accelerate.
Pull the control wheel backward to brake.

Before switching on, make sure that the acceleration and braking control wheel is in the neutral position. The screen on the remote control reminds you to move the control wheel to a neutral position, if this is not the case when switching on.



(6) Change the direction of movement of the E-longboard

If you want to reverse the direction of travel of the e-longboard, hold down the B-button on the remote control until it vibrates once briefly. Now you are driving in the direction of travel front-wheel drive. The arrow on the display of the remote control ("Direction of movement of the E-Longboard") now points downwards/rearwards.

You can change the direction of movement again via the "B-button" by pressing it for a long time. After the vibration, the E-Longboard moves again in the rear-drive direction. The arrow on the display of the remote control ("Direction of movement of the e-longboard") now points upwards/forwards.

Note: This function is only possible when the control wheel is in the neutral position (no acceleration) and the speed is less than 3 km/h.

(7) Changing the driving mode

Briefly press the "B-button". The remote control then switches to the next higher driving mode with a short vibration. drive mode (this process is only possible when the control wheel is in the neutral position). The gear symbol changes accordingly. There are 4 driving modes:

Mode 1: Slow, up to 15 mph

Mode 2: Medium, up to 20 mph

Mode 3: Fast, up to 30 mph

Mode 4: Turbo, up to 37mph

Note: For first-time use and beginners, we recommend using mode 1 (slow).

Cruise control: Turn the control wheel until you reach the desired speed.

Now press the "A" button, the remote control vibrates briefly and the symbol at the bottom left of the display becomes rectangular. Your speed will now be maintained. Press any button or turn the wheel to exit the mode.

(8) Charging

- 1 Charging the remote control: Connect the charging cable to the device and only then to the power outlet. When the charging starts, the remote control vibrates briefly. The charging process is displayed in real time on the screen of the remote control.

Note: While the remote control is charging, it cannot be operated. The remote control switches off automatically off and vibrates once briefly after the charging cable is disconnected.

- 2 Charging the E-Longboard: To charge the E-Longboard, it must first be switched off. Now connect the E-Longboard to the charger and then to the power outlet. The red indicator light on the Charger will light up. This indicates the charging is in process.

Note: Please do not use the E-Longboard during the charging process because parts of the control unit switch off during the charging process and thus no reliable control of the E-Longboard is possible. Furthermore the cable can be torn out and damage the charger or the socket.



05 / WARNINGS IN CASE OF MALFUNCTION

(1) Overcharging (e.g. when driving downhill with a fully charged battery)

We strongly advise against driving downhill with a fully charged battery, as the battery it is charged during braking. Thus, when driving downhill with a fully charged battery, the service life of the battery suffers considerably. If the user nevertheless drives downhill with a fully charged battery, the remote control will vibrate and the E-Longboard's power indicator will flash when the ESC (Electronic Speed Controller) detects that the battery voltage is too high. In this case, the user must consume some power before descending. Overcharging may cause the battery to catch fire or even explode.

If the user continues to ride downhill despite the warnings, the e-longboard will brake automatically to prevent the user from doing so. This method can only protect the battery to a limited extent and cannot provide a 100% guarantee for the safety of the battery and the user.

(2) Warning for loss of signal

In the event of a sudden loss of signal, the remote control screen will indicate the disconnection by a short vibration. If the E-Longboard is currently in the acceleration phase, this process will be slowly shutted down and then braking is slowly and automatically initiated. Outside of the acceleration phase, the e-longboard is automatically breaked down to the standstill.

In parallel, the remote control attempts to re-establish the connection to the E-Longboard. When it has reconnected successfully with the E-Longboard, the remote control vibrates briefly and the braking is cancelled.

(3) Lock warning

If the motor is blocked or completely stuck, this will be indicated on the remote control screen. In this case, the user should stop the operation of the e-longboard, check if there are any foreign objects in the motor and remove them properly before restarting the E-Longboard. If in doubt, contact a certified specialist workshop or customer support should be contacted.

motor recalibration:

In case you have any problems with your motors try to recalibrate your motors. You need to press the power button on your board 3 times. Note: board and remote must be switched on.



(4) Temperature alarm

When the operating temperature of the motor is above 212°F or below 37°F, the remote control vibrates once, the remote control screen displays the message "Over Temperature" appears on the remote control screen and the motor switches off.

Note: The user should pay attention to the motor temperature. If the motor temperature is too high, the user should stop operation and wait until temperatures have dropped and are back in the intended operating range. If the motor temperature is too low, the user should warm up the e-longboard slowly to above 37°F before starting operation. If the warm-up is too fast, condensation drops may occur which can damage the E-Longboard.

(5) Overvoltage alarm

If the operating current of the motor exceeds the permissible value, the screen of the remote control will display the message "Board over current". If this appears on the screen of the remote control the motor switches off.

Note: Turn off the E-Longboard immediately to avoid damage. Then restart it. It must not be used again until the warning message does not appear and the operating voltage is restored. If this is not the case, please contact our customer support.

06 / SAFE DRIVING

(1) Briefing

For protection, you should always wear a helmet, gloves, elbow and knee pads, as well as solid wear sturdy clothing/ protective gear to avoid serious injuries. Familiarize yourself with the E- Longboard before riding it. Make your turns slowly and carefully, and respect the braking distance.

It is recommended that you take your first ride on the E- Longboard in a safe area without any obstacles. Practice braking from different speeds. Furthermore, you should be aware of which leg is your "stronger" one.

We recommend positioning the stronger leg on the front of the e-longboard when riding in the direction of travel. This can be found out, for example, by having a second person hold someone (standing on solid ground, not on the E-Longboard) gently nudging from behind so that you one performs a lunge. The leg used for the lunge is the stronger one. The illustration again shows schematically the foot position on the E-Longboard. In the end it is up to you which position is more comfortable to ride.

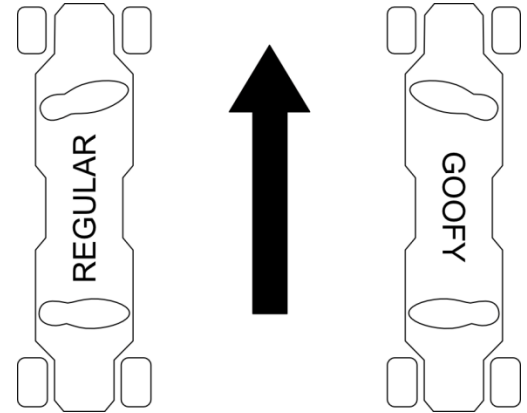



(2) Driving technique

- ① Foot position: As just shown, you ride with Regular (stronger right leg) or Goofy (stronger left leg) position. However, the foot position may vary during the ride if the load is distributed. Keep in mind to shift weight forward when accelerating and backward when braking, this improves control over the e-longboard

- ② Driving curves: Turning on the e-longboard is achieved by shifting your own body weight on the e-longboard. In curves, about 80% of the body weight is shifted to the front leg. In parallel, the body is tilted in the direction in which you want to move. The driving of the E-longboard is exactly like riding a non-electrified longboard and is also compared to snowboarding.

- ③ Please note: Like most sports, riding an e-longboard involves the risk of injury and damage. If you decide to ride the E-Longboard, you bear the responsibility and all associated risks. It is essential that you know, understand and follow the safety rules.

07 / CARE AND MAINTENANCE

(1) Range

The maximum range of the E-Longboard is influenced by many different factors:

- ① Driving surface: A smooth, flat surface extends the range.
- ② Weight: more weight means less range.
- ③ Ambient temperature: Please ride and store the E-Longboard below the recommended temperature to increase its longevity and range.
- ④ Diameter of the wheels: Larger wheels reduce the range.
- ⑤ Speed and riding style: Maintaining a moderate speed increases the range. Frequent starting and stopping, accelerating and decelerating will reduce the range of the E-Longboard.

(2) Maximum speed

The maximum speed is approx. 37 mph, depending on the user's body weight and the diameter of the wheels used. (the larger the wheel diameter, the higher the maximum speed).



(3) Weight limit

The E-Longboard may only be used by one person at a time. The maximum load is 440lbs. Exceeding the maximum weight may cause damage to the E-Longboard.

(4) Cleaning the E-longboard

To clean the downside of the E-Longboard and the wheels, wipe them gently with a damp cloth and then dry them with a dry cloth. Do not wipe the top of the of the E-Longboard. Do not use water to clean the E-Longboard, as the electrical components and the battery may become wet, which can lead to damage or malfunction of the E-Longboard.

(5) Battery

- ① Keep the E-Longboard away from fire and excessive heat. Very low temperatures should also be avoid.
- ② To avoid damaging the battery, never subject the E-Longboard to strong physical shocks, strong vibrations or shocks
- ③ Protect the E-Longboard from water (rain/snow etc.) and moisture.
- ④ Never disassemble the E-Longboard or the battery.
- ⑤ If there are any problems with the battery, please contact Cavity Customer Service or send us an E- mail to support@cavityboards.com

Note: Promote battery longevity when used between 20%-80% of battery capacity

(6) Storage

- 1 If you plan to store the E-Longboard for a long period of time, make sure that you charge the battery up to 80% before storing it. The battery level should not fall below 20% in order not to endanger the life of the battery.
- 2 Cover the E-Longboard to protect it from dust.
- 3 Store the E-Longboard in a dry room and at a suitable temperature.
- 4 You should bring the E-Longboard to charge in an environment with room temperature (20° C/ 68° F).
- 5 Do not leave the E-Longboard permanently connected to the charger, but disconnect it after the battery is fully charged.



08 / SAFETY INSTRUCTIONS

(1) Changes

Do not attempt to disassemble, modify, repair, or replace the E-Longboard or any component of the unit without the instruction of Cavity Customer Service without instructions to disassemble, modify, repair or replace. This will invalidate the operating permit and any guarantee and can lead to malfunctions that can cause injuries.

(2) Additional safety instructions for operation

Do not pick up the E-Longboard from the ground when it is turned on and the wheels are in motion. This can cause the wheels to spin freely, which may result in injury to you or others nearby.

Do not jump on or off the e-longboard or jump on it while using it.

Always check the battery charge level before use.

09 / WARRANTY

(1) To claim the warranty

We offer 1 year warranty on the battery and 2 years warranty on the e-longboard and the other components.

Cavity boards are built with the best configuration of motors, controllers and batteries. We test all parts and run each Cavity E-Longboard for 240 minutes before we pack it for shipping. Warranty claims can be sent back to us. We will handle the shipping and repair of the e-Longboard.

You can also find the spare parts for it in our online store. If not, please contact us at support@cavityboards.com.

We offer this e-longboard with a warranty of 2 years and the battery with 1 year.

No warranty cases are:

Water damage, damage from improper use such as jumps, stunts, improper physical impact, failure to maintain maximum weight, braking downhill with a fully charged battery, damage caused by accidents, independent repairs without our approval, modification of the product, misuse, force majeure and insufficient care. This also includes wear parts such as wheels, rollers, bearings, belts or gears. In the event of a warranty claim, please contact our support and retain the shipping carton in case you need to send in your e-longboard.



(2) Declaration of warranty

- ① The warranty is only valid for E-Longboards purchased from the official Cavity homepage or from an authorized dealer.
- ② Contractual claims can only be asserted for the specific product in its concrete specification, painting and configuration existing at the time of delivery.
- ③ The manufacturer's warranty covers workmanship and material defects.
- ④ Please keep the shipping carton. The warranty does not apply to damage caused by return shipment in inadequate packaging.

10 / DEVELOPER MODE

(1) enter developer mode

Press button "B" eight times to enter the developer mode. Here you can modify the settings in case you need to change your battery setup, drive system, modify your speedmodes or restore all parameters.

(2) settings

1. speed mode: (a) duty (b) speed
2. motor run mode: (a) hybrid (b) full sense
3. max speed : set overall max speed
4. batt out max: set maximum output of the battery
5. batt cells: choose your battery setup
6. batt type: (a) 21700 lithium ion cells (b) Li-pol cells
7. driver freq: choose between different frequencies
8. max break: set overall max break
9. motor run dir: change motor run direction
10. L mode ref: set value referred to max break & max speed (mode L)
11. L mode cur: set max current (mode L)
12. L speedup line : set acceleration curve (mode L)
13. L break line: set break curve (mode L)
- 14.-17. set values mode E
- 18.-21. set values mode S
- 22.-25.. set values mode S+
26. restore para: restore all parameters (yes) or (no)



ENJOY YOUR RIDE!



OFFICIAL WEBSITE

SUPPORT@CAVITYBOARDS.COM
+4915209611547